

ENGINE TESTS AND BOILER EFFICIENCIES

Published @ 2017 Trieste Publishing Pty Ltd

ISBN 9780649269464

Engine tests and boiler efficiencies by J. Buchetti

Except for use in any review, the reproduction or utilisation of this work in whole or in part in any form by any electronic, mechanical or other means, now known or hereafter invented, including xerography, photocopying and recording, or in any information storage or retrieval system, is forbidden without the permission of the publisher, Trieste Publishing Pty Ltd, PO Box 1576 Collingwood, Victoria 3066 Australia.

All rights reserved.

Edited by Trieste Publishing Pty Ltd.
Cover @ 2017

This book is sold subject to the condition that it shall not, by way of trade or otherwise, be lent, re-sold, hired out, or otherwise circulated without the publisher's prior consent in any form or binding or cover other than that in which it is published and without a similar condition including this condition being imposed on the subsequent purchaser.

www.triestepublishing.com

J. BUCHETTI

**ENGINE TESTS AND
BOILER
EFFICIENCIES**

TEMP
B

ENGINE TESTS AND BOILER EFFICIENCIES

BY
J. BUCHETTI

Sometime Professor at the Central Technical School, Paris.

TRANSLATED AND EDITED FROM THE THIRD EDITION
BY ALEXANDER RUSSELL, M.I.E.E., ETC.

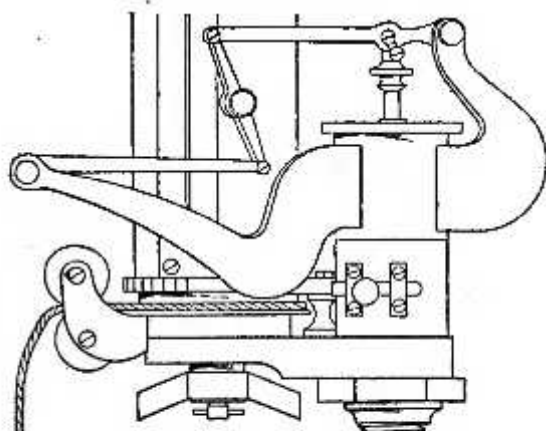

82926
21/8/04

WESTMINSTER
ARCHIBALD CONSTABLE & CO LTD
2 WHITEHALL GARDENS

1923

AUTHOR'S PREFACE TO THE THIRD EDITION

IN this edition I have made considerable alterations and additions in almost every chapter of the book, especially in those parts which are concerned with the theory of indicators, the analysis of the working of their various parts, the description of new apparatus, such as indicators, with exterior springs for use with high pressure engines or when the steam has been superheated, explosion recorders for gas, petrol or alcohol engines, apparatus for reducing the scale of the reciprocating motion and the methods of setting it up, apparatus for verifying the flexibility of the springs of the indicators, etc. I have also made some additions to the chapter on brakes. In the second edition I had added a chapter on transmission dynamometers for use in measuring the work transmitted from the prime mover to the machine which it drives. This chapter, however, grew so large, especially that part of it which dealt with the theory of the dynamo-brake, that it appeared better to make this the subject of a separate book.

J. BUCHETTI.

PUBLISHER'S NOTE

IT has been thought that a translation of Mr. Buchetti's standard work "Guide pour l'essai des moteurs" should prove useful to English and American engineers, as it would enable them to compare the best continental practice with that in use in their own countries. With this end in view the measures and tables have in every instance been converted into English units. The formulæ also have been adapted into English measure. It is unnecessary for us to speak of the great value and striking originality of Mr. Buchetti's work.

We are indebted to the Hon. C. A. Parsons, F.R.S., for a brief chapter on testing steam turbines, a subject which is not touched upon by the author.

TABLE OF CONTENTS

	PAGE
Author's Preface to the Third Edition	v
Publisher's Note	vii

CHAPTER I

INDICATORS

Watt, MacNaught, Hopkinson. Figs. 1-4	1
M. P. Garnier (annuls inertia effects). Figs. 5, 6	4
Richards' Indicator, Elliott Brothers. Figs. 7, 8	7
Darke's Indicator, for high pressures, Elliott Brothers. Fig. 9	8
Thompson's Indicator	10
P. Garnier's Indicator for high pressures and speeds. Fig. 13	10
Martin-Garnier's Indicator (annuls jerking of the drum). Figs. 15-17	11
P. Garnier's Magazine drum (rigidly driven). Figs. 18-21	13
Schaeffer and Budenberg Indicator. Fig. 22	15
Rosenkranz's Indicator	16
Dreyer-Rosenkranz and Droop. Fig. 23	16
Crosby's Indicator (double spiral spring). Figs. 24-26	16
Indicator with external spring, Elliott Brothers. Figs. 27, 28	18
Rosenkranz's Indicator with exterior spring. Figs. 29, 30	19
Kenyon's Indicator (elastic tube). Fig. 31	21
Prussmann's Differential Indicator, Schaeffer and Budenberg. Fig. 32	22

CONTENTS

CHAPTER II

CONTINUOUS INDICATORS

	PAGE
Guinotte's Indicator and diagrams. Figs. 34-36	25

RECORDING INDICATORS.

Ashton and Storey's Indicator. Figs. 37-41	28
Calculation of the diameter of the wheel to give 1,000 foot-pounds per revolution of index	33
H. Lea's Planimeter Indicator. Figs. 42, 43	34
Theory, Calculation of Work, manipulation. Fig. 44	35
Boys' Indicator. Figs. 45-47	38
Mechanism of the Integrator	38
Calculation of the Work	40

CHAPTER III.

ON MOUNTING INDICATORS.

<i>General Arrangements.</i> Figs. 49, 51, 52, 53, 54, 58, 60, 61	41
---	----

TRAVEL REDUCING GEAR.

Stanek's Apparatus. Figs. 62, 63	47
Various Apparatus. Figs. 64-67	49
P. Garnier's Apparatus. Figs. 68-70	50
Calculating the diameter of the little Pulley	51
Crosby's Reducing Gear. Fig. 71	52
Electric control of Pencil (Kovarik's system). Fig. 74	53
Perry's Optical Indicator. Figs. 76-78	55

CHAPTER IV.

THEORY OF THE INDICATOR.

Plunger Tests—the Scale of the Spring (hot and cold). Figs. 83-85	58
Relation between the movement of the Plunger and that of the Pencil	63

CONTENTS

	PAGE
The Pencil or Tracer, vibration of Pencil	65
The Paper Drum. Cord. Drum worked by non-flexible rod, Figs. 94, 95	68

CHAPTER V.

THE STUDY OF DIAGRAM.

The Diagram. Advance Admission	71
Rapid action of Steam. Duration of Admission	74
Expansion. Two-Cylinder Engines	78
Steam Jacketing. Mariotte's or Boyle's Curve	81
Graphical Method. Advance of Exhaust	84
Exhaust and Back Pressure. Compression	86
The Compression Curve. Determination of Clearance Space	89
Expansion in Compound Two-Cylinder Engines	90
Diagrams of Compound Engine. Figs. 110-112	91
Diagrams of Woolf Engine. Fig. 113	93
Diagram of a Triple Expansion Engine. Fig. 114	93
Causes of errors in Diagrams. Various	94
Applications of Indicator. Steam Chest. Exhaust Pipe	95
Use of Indicator in Hydraulic Work	98

CHAPTER VI.

TESTING GAS AND OIL ENGINES.

Ordinary Diagram of a Gas Engine (Otto). Fig. 118	100
Mathot's Registering Indicator, M. Garnier. Figs. 119, 120	101
(1) Testing the Value of the Compression. Fig. 121	102
(2) Finding the Resistance to Admission and Exhaust (dia- grams). Figs. 122, 123	103
(3) Comparing the Mean Power of Explosions by means of Ordinates in juxtaposition. Fig. 124	105
(4) Analysis of the Cycle by four diagrams representing the four Periods. Fig. 125.	105
(5) Analysis of the effects of inertia on the Recorder. Choice of a suitable Spring (diagram). Fig. 126	106

CONTENTS

CHAPTER VII.

MEASUREMENT OF THE INDICATED HORSE POWER.

	PAGE
Mean Ordinate. Trapezium Method. Fig. 127	109
Graham's Screw (Fig. 128). Another Method. Fig. 129.	110
Simpson's Method (Fig. 130). Observations. Fig. 131	112
Amsler's Planimeter. Theory. Figs. 132-137	114
Revolution Counters. A. Sainte's Counter. Fig. 138	120
Calculation of the Indicated Power	121
Values of the Ratio $\eta = \frac{H}{H'}$. Calculation of the diameter of the Piston	124
Work on friction. Diagram at no load. Inertia of the Fly-wheel	125

CHAPTER VIII.

MEASUREMENT OF THE BRAKE HORSE POWER.

§ 1. Ordinary Brake. Prony. Fig. 140	129
Construction. Figs. 145 and 141	130
Vertical Shaft. Figs. 142, 143	131
Calculation of the Effective Work	134
Calculation of the Dimensions of a Brake—Pulley. Bolts. Example. Lever	136
Various Constructions. Detachable Brake. Fig. 146	141
Brake of the Société Centrale (water-cooled). Fig. 147	143
Thiabaud Brake. Results with this Brake. Figs. 148, 149	144
Carpenter's Hydraulic Brake. Figs. 150-152	146
§ 2. Automatic Brakes	148
Brake with Spring Balance. Fig. 153	148
The Creuzot Arrangement. Calculation of Work. Fig. 154	149
Amos or Appold Brake (Royal Agr. Soc.). Figs. 155-157	151
Balk Brake—mounted on Trolley. Fig. 159	154
Brauer Brakes (three arrangements). Figs. 160-162	155
Beer or Fetu-Deliège Brake. Fig. 163	160
Cadiat Brake. With hanging weights. Fig. 164	161